

DOOR LIFT



DL - 250

DL - 250

- EASY TO OPERATE.
- FOOT OPERATED HYDRAULIC JACK
- ADJUSTABLE MOUNTINGS.
- FULLY INSULATED CONTACT POINTS.
- SWIVEL CASTOR WHEELS
- BRAKE SYSTEM.
- DESIGN FOR MULTI FIT SPECIFICATION.

ITEM No.	CAPACITY	KG	LIST PRICE
DL - 250	250KG	250	£573.46

POWER TRAIN HOIST

- FLEXIBLE USE.
- DOUBLES AS ENGINE CRANE.
- EQUIPPED WITH NEW AIR HYDRAULIC PUMP.
- PRECISE HAND PUMP CONTROL.
- HEAVY DUTY STEEL CONSTRUCTION.
- WIDE BASE DESIGN.
- REAR SWIVEL CASTORS.
- PORTABLE AIR VALVE CONTROL.



EC-300C

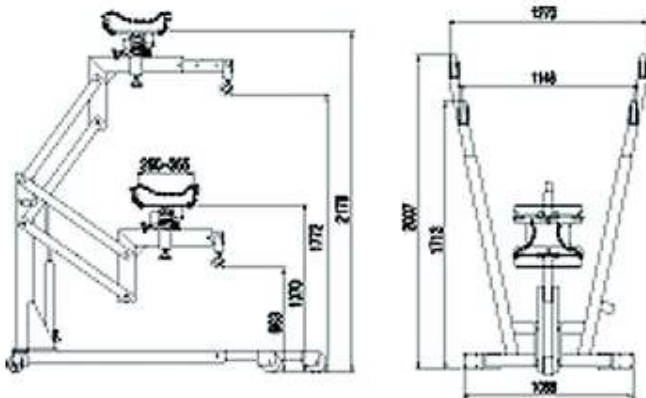

EC - 300C

ITEM No.	CAPACITY	KG	LIST PRICE
EC - 300C	750KG	167.3	£1222.71