

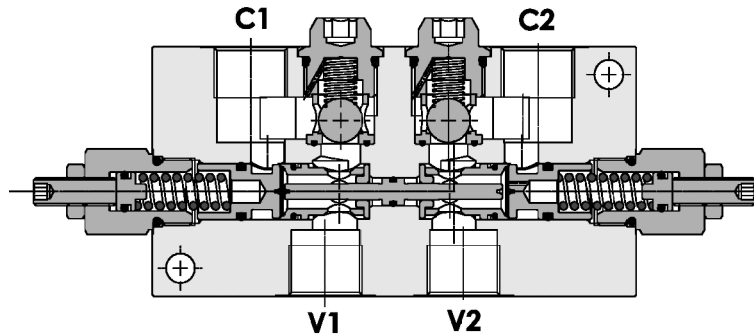

Valvola overcenter doppia, montaggio in linea, serie E
Dual overcenter valve, line mounted, E series

Rev.03-2022/08

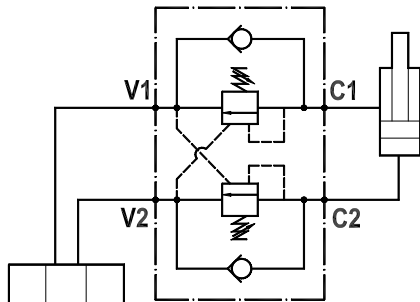

SPECIFICHE TECNICHE

Materiali: corpo in alluminio. I componenti interni sono in acciaio trattato termicamente.

Portata max.: 120 l/min

Taratura max.: 350 bar

Rapporto di pilotaggio: 1 : 3.2 (a richiesta 1 : 8.2)

Regolazione pressione: mediante vite

Campo di regolazione pressione: vedere pag.02

Peso: 1,770 Kg

TECHNICAL SPECIFICATIONS

Materials: body is in aluminium alloy. Internal parts are in hardened steel.

Rated flow: up to 120 l/min

Max. setting: 350 bar

Pilot ratio: 1 : 3.2 (standard), 1 : 8.2 on request

Adjustment means: leakproof screw adjustment

Adjustable pressure range: see page 02

Weight: 1,770 Kg

DIAGRAMMA PERDITE DI CARICO PRESSURE DROP CURVES

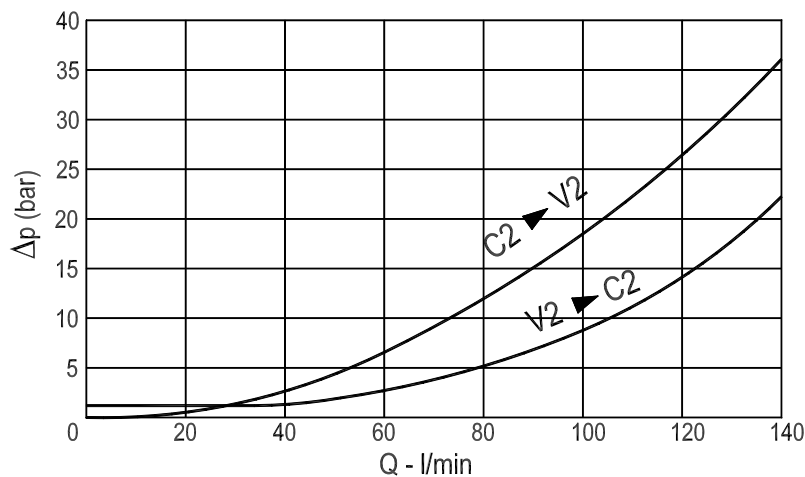



Valvola overcenter doppia, montaggio in linea, serie E
Dual overcenter valve, line mounted, E series

Rev.03-2022/08

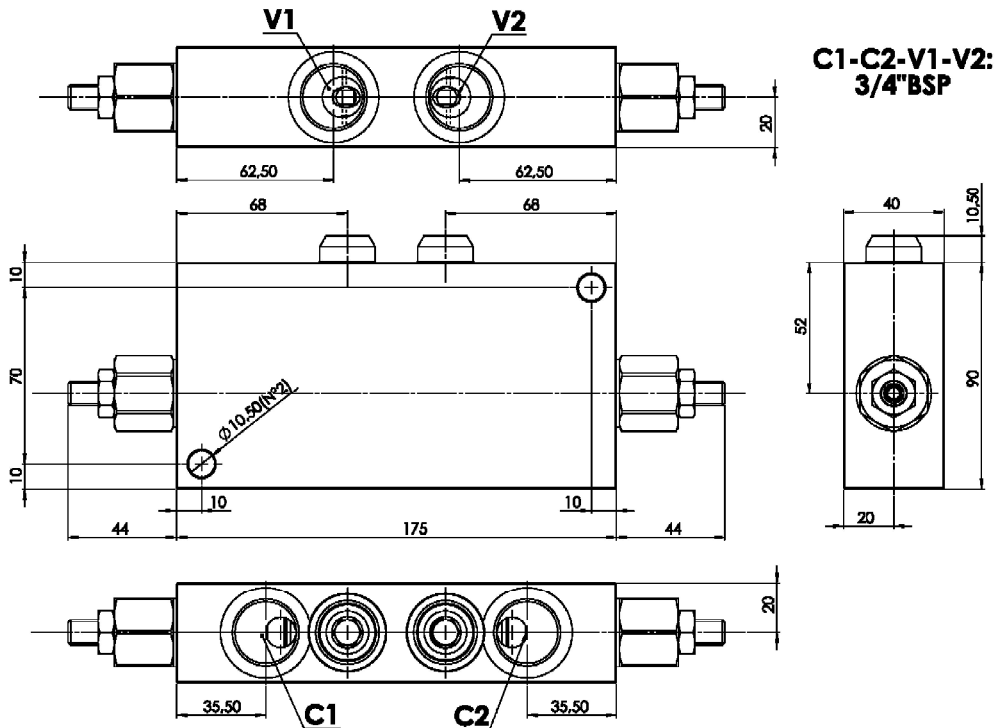

MOLLE - SPRINGS				*
Codice Code	Rapp. pil. Pilot ratio	Campo taratura min.-max. bar Adjustable pressure range bar	Increment. press. bar/ giro vite Pressure increase bar/turn	Taratura standard bar Standard setting bar
20	1 : 3.2	60 - 210	56	200
	1 : 8.2	60 - 210	56	200
35	1 : 3.2	120 - 350	120	350
	1 : 8.2	120 - 350	120	350

ESEMPIO DI ORDINAZIONE - ORDERING CODE EXAMPLE

F P O E **1 2 0** **D** **3 / 4** **L** **A** **2 0** **B**

* $\pm 20\% / \pm 5\%$
 Campi di taratura pressione - Adjustable pressure range

Rapporto di pilotaggio
 Pilot ratio
 Omettere se standard *
 Omit if standard
 B = 1 : 8.2