



Tipo / Type

FPO-*-D-*-2F-*-**

Sez./Section

O

Pag./Page

470/1

Valvola overcenter doppia, montaggio a flangia
Dual overcenter valve, gasket mounted

Rev.06-2022/07

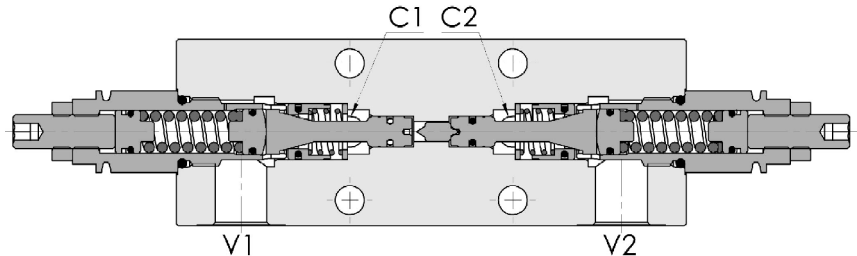
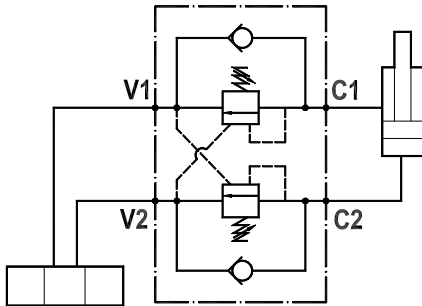

SPECIFICHE TECNICHE

Materiali: corpo in acciaio zincato. I componenti interni sono in acciaio trattato termicamente.

Portata max.: 70 l/min

Taratura max.: 350 bar

Rapporto di pilotaggio: 1 : 4.25 (a richiesta 1 : 2.7, 1 : 8, 1 : 11)

Regolazione pressione: mediante vite

Campo di regolazione pressione: vedere pag. 02

TECHNICAL SPECIFICATIONS

Materials: body is steel made, zinc plated. Internal parts are in hardened steel.

Rated flow: up to 70 l/min

Max. setting: 350 bar

Pilot ratio: 1 : 4.25 (1 : 2.7, 1 : 8 and 1 : 11 on request)

Adjustment means: leakproof screw adjustment

Adjustable pressure range: see page 02

DIAGRAMMA PERDITE DI CARICO PRESSURE DROP CURVES

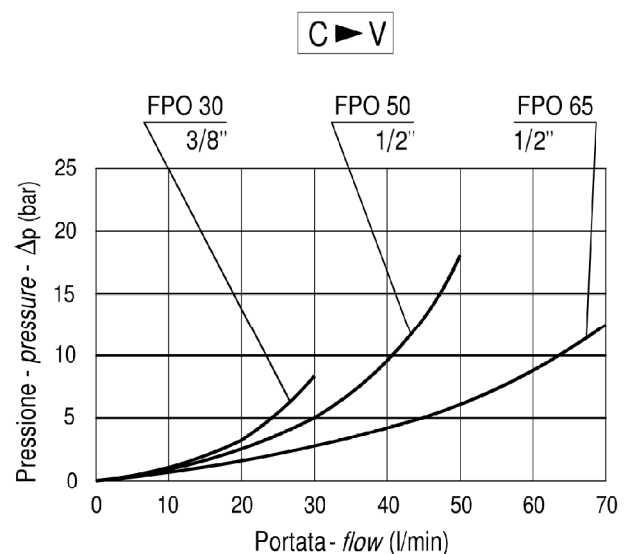
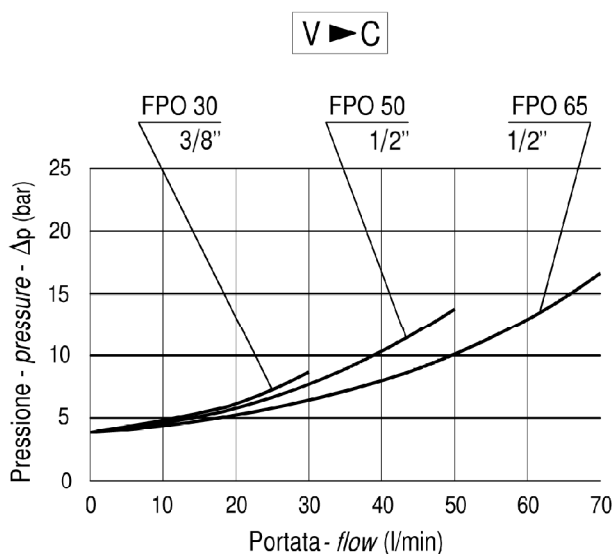



Valvola overcenter doppia, montaggio a flangia
Dual overcenter valve, gasket mounted

Rev.06-2022/07

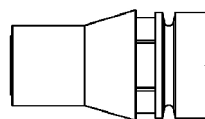
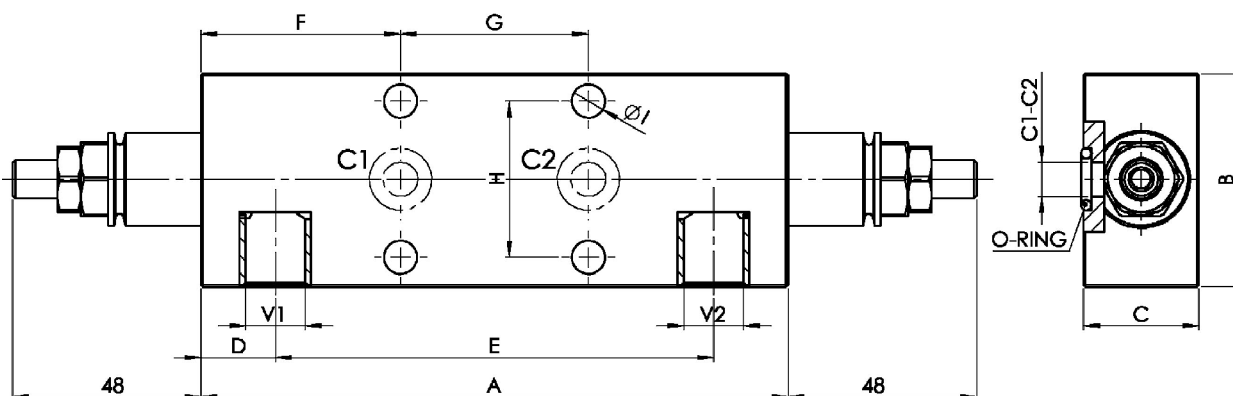

Cappello antimanomissione.
Codice di ordinazione: 9006800010

Tamperproof cap.
Ordering code: 9006800010

MOLLE - SPRINGS				*
Codice Code	Rapp. pil. Pilot ratio	Campo taratura min.-max. bar Adjustable pressure range bar	Increment. press. bar/giro vite Pressure increase bar/turn	Taratura standard bar Standard setting bar
20	1 : 2.7	70 – 230	70	170
	1 : 4.25	60 – 210	42	
	1 : 8	60 – 220	50	
	1 : 11	60 – 250	70	
35	1 : 2.7	120 – 330	80	280
	1 : 4.25	80 – 350	107	
	1 : 8	100 – 350	78	
	1 : 11	80 – 350	109	

TIPO TYPE	V1-V2	C1-C2	O-RING	A	B	C	D	E	F	G	H	I	PESO WEIGHT
	BSPP	mm	mm	mm	mm	mm	mm	mm	mm	mm	mm	mm	Kg
FPO * D 3/8 2F	3/8"	9	10.77X2.62	150	55	29.5	19	112	51	48	40	8.5	1,820
FPO * D 1/2 2F	1/2"	9	10.77X2.62	150	65	34.5	19	112	51	48	40	8.5	2,400

ESEMPIO DI ORDINAZIONE - ORDERING CODE EXAMPLE

F P O * **D** * **2 F** * * *

* $\frac{90}{100} + / \frac{95}{100} + / \frac{65}{65} \pm$
 Portata massima . Rated flow

* $\frac{3}{8}$. $\frac{3}{8}$ " BSPP
 $\frac{1}{2}$. $\frac{1}{2}$ " BSPP (50/65)
 Connessioni - Port sizes

* $\frac{90}{100} + / \frac{95}{100} \pm$
 Campi di taratura pressione - Adjustable pressure range

Guarnizioni . Seals:
 V=Viton *
 Omettere se BUNA-N . Omit if BUNA-N

B = 1 : 8, C = 1 : 11, D = 1 : 2.7
 Rapporto di pilotaggio . Pilot ratio *
 Omettere se standard . Omit if standard