

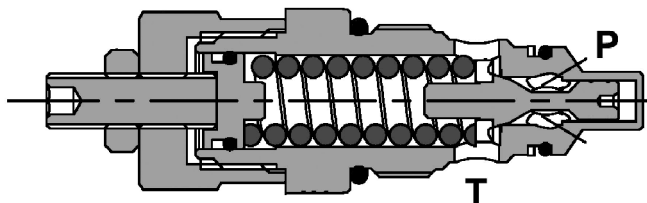
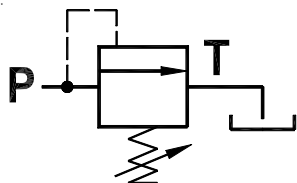

Valvola di regolazione pressione con cono guidato ad azione diretta, cavità SAE
Direct acting, guided poppet style relief valve, SAE cavity

Rev.03-2022/04

**SPECIFICHE TECNICHE**

Materiali: cartuccia in acciaio zincato, parti interne in acciaio trattato termicamente.

Portata: 70 l/min

Taratura max.: 350 bar

Regolazione pressione: mediante vite

TECHNICAL SPECIFICATIONS

Materials: cartridge in steel zinc plated, internal parts are in hardened steel.

Rated flow: 70 l/min

Max. setting: 350 bar

Adjustment means: leakproof screw

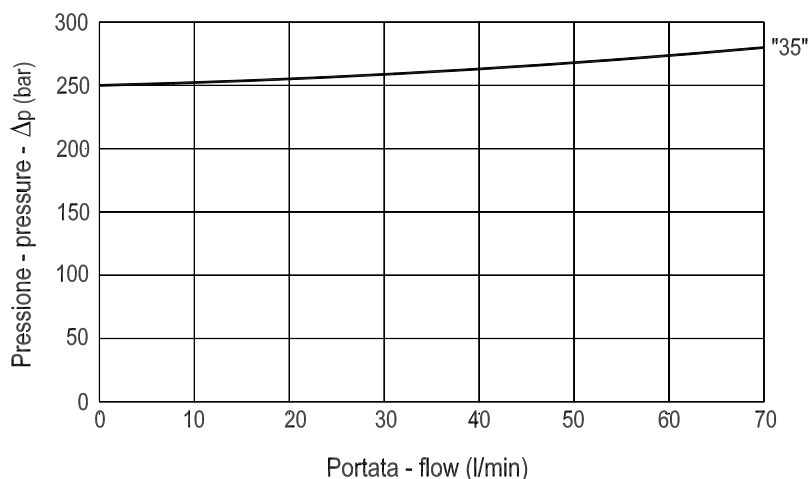
DIAGRAMMA PERDITE DI CARICO
PRESSURE DROP CURVES



Valvola di regolazione pressione con cono guidato ad azione diretta, cavità SAE
Direct acting, guided poppet style relief valve, SAE cavity

Rev.03-2022/04

MOLLE - SPRINGS				*
Codice Code	Campo taratura min.-max. bar Adjustable pressure range bar	Increment. press. bar/giro vite Pressure increase bar/turn	Taratura standard bar Standard setting bar	Colore Color
20	40 - 200	/	40	/
35	100 - 350	/	100	/

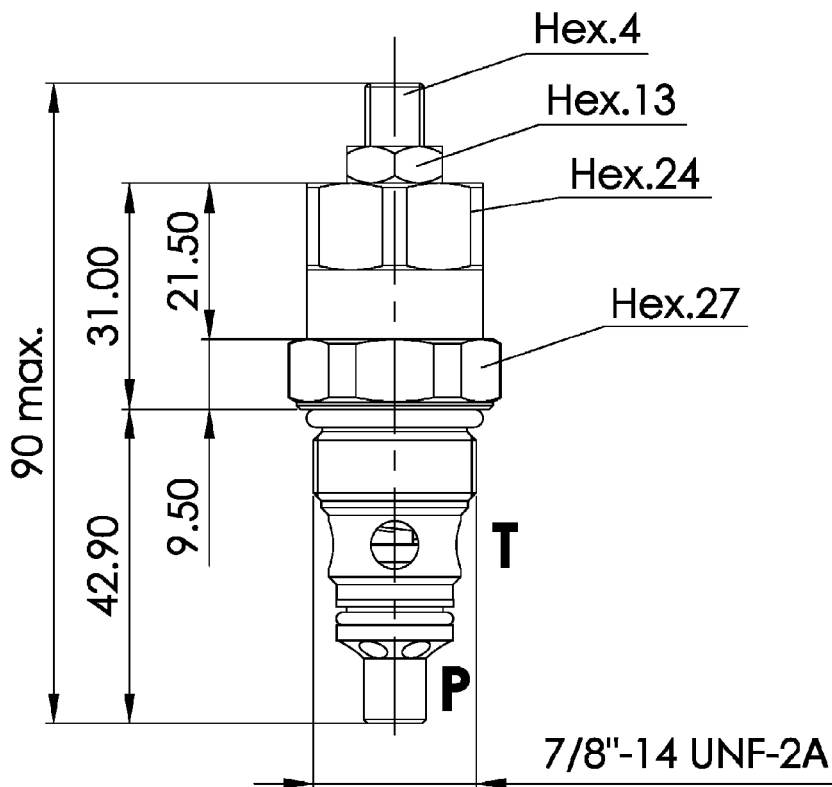

TIPO TYPE	CAVITA' CAVITY	COPPIA DI SERRAGGIO INSTALLATION TORQUE	PESO WEIGHT
		Nm	Kg
FPM D S10 C	23102	35 - 38	0.170

ESEMPIO DI ORDINAZIONE - ORDERING CODE EXAMPLE

F P M D S 1 0 C P 2 0

20+ / 35± *

Campi di taratura pressione . Adjustable pressure range